



TURNING TOOLS

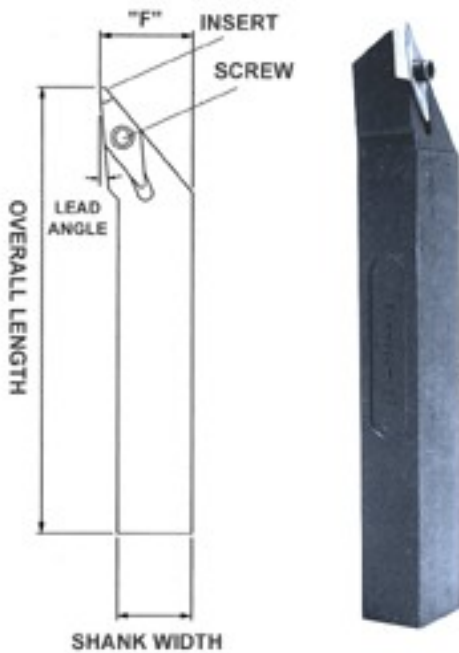

FIG. 1

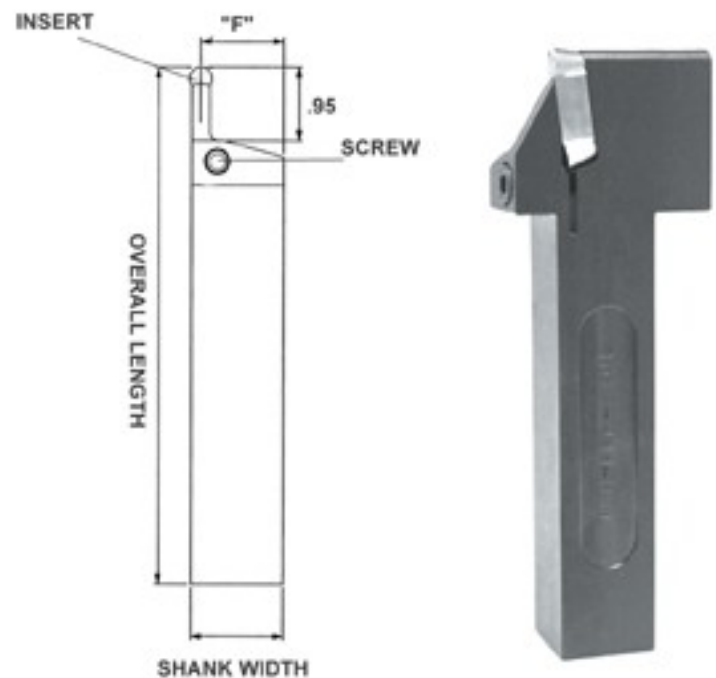

FIG. 2

FIG.	PART NO.	INSERT TYPE	SHK SIZE	OVERALL LENGTH	LEAD ANGLE	SCREW TYPE	"F" DIM
2	TNH-FJG-840R	GIDA-8.0-4.0 CARBIDE OR PCD	1 x 2.25 x 6	6.000	0°	M6 x 20 SHCS	1.250
1	TNH-FFG-050R	VPGA/Z-443 CARBIDE OR PCD	1 x 1 x 6	6.000	5°	10-32 x 3/4 SHCS	1.250
1	TNH-FFG-050L	VPGA/Z-443 CARBIDE OR PCD	1 x 1 x 6	6.000	5°	10-32 x 3/4 SHCS	1.250
2	TNH-FFG-630R	GIPA-6.0-3.0 CARBIDE OR PCD	1 x 1 x 6	6.000	0°	M6 x 20 SHCS	0.903
2	TNH-FFG-840R	GIDA-8.0-4.0 CARBIDE OR PCD	1 x 1 x 6	6.000	0°	M6 x 20 SHCS	0.875
2	TNH-FFG-840L	GIDA-8.0-4.0 CARBIDE OR PCD	1 x 1 x 6	6.000	0°	M6 x 20 SHCS	0.875
1	TNH-HHG-050L	VPGA/Z-443 CARBIDE OR PCD	1.25 x 1.25 x 7	7.000	5°	10-32 x 3/4 SHCS	1.500
1	TNH-HHG-050R	VPGA/Z-443 CARBIDE OR PCD	1.25 x 1.25 x 7	7.000	5°	10-32 x 3/4 SHCS	1.500
1	TNH-HHG-275R	VPGA/Z-443 CARBIDE OR PCD	1.25 x 1.25 x 7	7.000	27.5°	10-32 x 3/4 SHCS	1.875
2	TNH-HHG-630R	GIPA-6.0-3.0 CARBIDE OR PCD	1.25 x 1.25 x 7	7.000	0°	M6 x 20 SHCS	1.153
2	TNH-HHG-840R	GIDA-8.0-4.0 CARBIDE OR PCD	1.25 x 1.25 x 7	7.000	0°	M6 x 20 SHCS	1.125
2	TNH-HHG-840L	GIDA-8.0-4.0 CARBIDE OR PCD	1.25 x 1.25 x 7	7.000	0°	M6 x 20 SHCS	1.125
1	TNH-SSG-050R	VPGA/Z-443 CARBIDE OR PCD	1 x 1.25 x 8.5	8.500	5°	10-32 x 3/4 SHCS	1.500
1	TNH-SSG-050L	VPGA/Z-443 CARBIDE OR PCD	1 x 1.25 x 8.5	8.500	5°	10-32 x 3/4 SHCS	1.500
1	TNH-SSG-150R	VPGA/Z-443 CARBIDE OR PCD	1 x 1.25 x 8.5	8.500	15°	10-32 x 3/4 SHCS	1.500
1	TNH-SSG-150L	VPGA/Z-443 CARBIDE OR PCD	1 x 1.25 x 8.5	8.500	15°	10-32 x 3/4 SHCS	1.500
1	TNH-SSG-220R	VPGA/Z-443 CARBIDE OR PCD	1 x 1.25 x 8.5	8.500	22°	10-32 x 3/4 SHCS	1.500
1	TNH-SSG-220L	VPGA/Z-443 CARBIDE OR PCD	1 x 1.25 x 8.5	8.500	22°	10-32 x 3/4 SHCS	1.500

ASI WORKHOLDING, INC.

1258 Fendt Drive, Howell, MI 48843 517-540-0400 Fax: 517-540-0375 toolsales@asichuck.com